



DL

DECORATIVE LABELING

THERMOFLOW® STANDALONE STEAM SHRINK TUNNEL SYSTEM



Standalone, integrated steam tunnel and low pressure steam generator provides high performance shrink option for plants without steam boilers

ThermoFlow® standalone steam shrink tunnels offer high quality shrink performance that only steam can provide with the convenience of an integrated, self contained steam generator.

When supplied with water and electricity, ThermoFlow systems automatically generate high quality, low pressure steam and directly supply it to an integrated shrink tunnel.

ThermoFlow integrated steam tunnels eliminate the need for costly centralized steam generation systems. They offer tool-less container changeovers and the changeover process is simple, intuitive and repeatable.

FEATURES AND BENEFITS

- **Size range flexibility** - Container or multi-pack diameters up to 6" and heights up to 12"
- **Tool-less size changeovers** - Fast, simple container changeovers increase uptime and enhance productivity
- **Stainless steel construction** - Durable, easy to clean, easy to maintain
- **Clear lift-off front panel** - Makes access to all key system components easy and convenient
- **Temperature control** - Simple manual adjustments of steam exhaust quickly increase or decrease tunnel temperatures - no complicated electronics to worry about
- **Adjustable steam distribution** - Perforated steam bars are easily positioned to achieve optimum shrink results

SHRINK APPLICATIONS

Like every Axon shrink tunnel, ThermoFlow offers the flexibility to perform multiple shrink applications. This flexibility makes Axon shrink sleeve applicators one of the best values in the industry.



FULL BODY



FULL BODY OVER THE CAP



TAMPER EVIDENT



PARTIAL



MULTIPACK

AXON THERMOFLOW® STANDALONE STEAM SHRINK TUNNEL SYSTEM

TYPICAL PRODUCT SPECIFICATIONS

Max. Container Size	6" wide x 12" tall*	Footprint	38" x 52" x 68.25"
Water	11 gallons / hr	Boiler	30kw, 10psi
Power	480 VAC, 3-phase, 36 AMPS - steam generation 110 VAC, 1-phase, 15 AMPS - controls		

* Dependent on product size and shape

CONFIGURATION

Top view

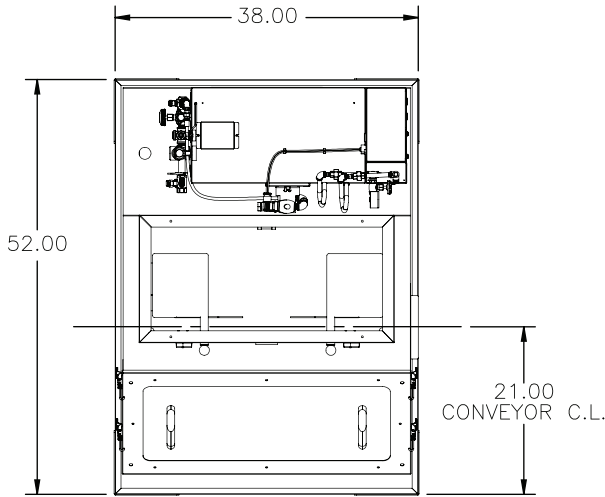

Dimensions are in inches

Front view

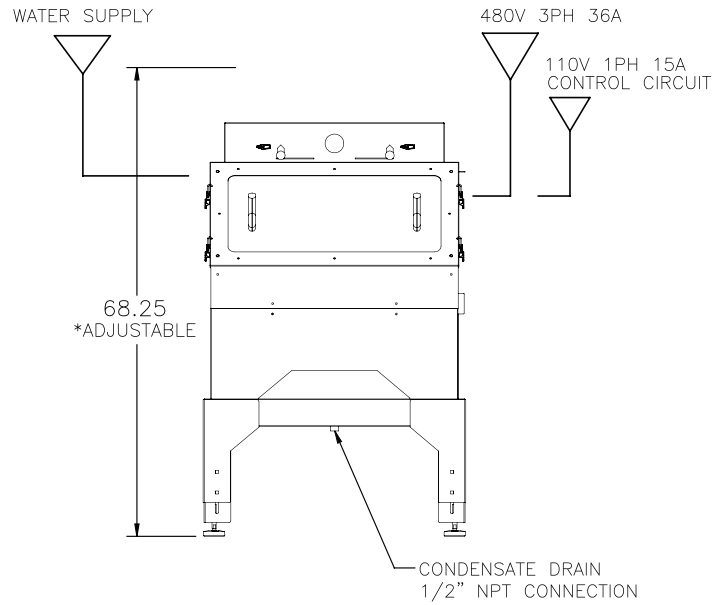

OPTIONS

- **Steam capture** - Traps exhaust steam for ventilation outside of environment
- **Third steam zone** - Enhanced shrink performance
- **Spare parts kit** - Recommended start-up parts inventory

SHRINK APPLICATIONS



FULL BODY



FULL BODY OVER THE CAP



TAMPER EVIDENT



PARTIAL



MULTIPACK

©2025 ProMach Inc. ProMach reserves the right to change or discontinue specifications and designs shown in this brochure without notice or recourse
PM-AX-SP110_Axon_ThermoFlow_0719v2_Web

PHONE
919-772-8383

EMAIL
Axon@ProMachBuilt.com

WEB
AxonCorp.com

Axon LLC
3080 Business Park Dr, Suite 103
Raleigh, NC 27610